

*A: Monitor shown is a standard 17" monitor, shown for concept and scale. Customer monitor dimensions may vary.
 *B: Dimensions shown are based on the angle of the 22-06-1 arm, dimensions may vary based on position.

PROPRIETARY AND CONFIDENTIAL
 THE INFORMATION CONTAINED IN THIS DRAWING IS THE SOLE PROPERTY OF <INSERT COMPANY NAME HERE>. ANY REPRODUCTION IN PART OR AS A WHOLE WITHOUT THE WRITTEN PERMISSION OF <INSERT COMPANY NAME HERE> IS PROHIBITED.

		UNLESS OTHERWISE SPECIFIED:		NAME	DATE	
		DIMENSIONS ARE IN INCHES	DRAWN	SJB	06/21/17	TITLE: 60221P-10-65-B
		TOLERANCES:	CHECKED			1 1/2" Pole Clamp with Split Sleeves and 6.5" arm
		FRACTIONAL ±	ENG APPR.			
		ANGULAR: MACH ± BEND ±	MFG APPR.			
		TWO PLACE DECIMAL ±	Q.A.			
		THREE PLACE DECIMAL ±	COMMENTS:			
		INTERPRET GEOMETRIC TOLERANCING PER:				SIZE DWG. NO. REV
		MATERIAL				A 60221P-10-65-B
NEXT ASSY	USED ON	FINISH				SCALE: 1:8 WEIGHT: SHEET 1 OF 2
APPLICATION		DO NOT SCALE DRAWING				

Drawing #: 60221P-10-65-B
 Assembly Drawing

ITEM	#60221P-10-65-B Parts	DESCRIPTION	QTY
1	25-42-Q-B	1.5" Pole Clamp	1
2	25-42-SS	Split Sleeves	1
3	22-06-1-B	6.5" Extension Arm	1
4	21-01-B	Pivot Bracket	1
5	21-02-B	Adaptor Plate	1
6	17" MON	17" Monitor (*A)	1

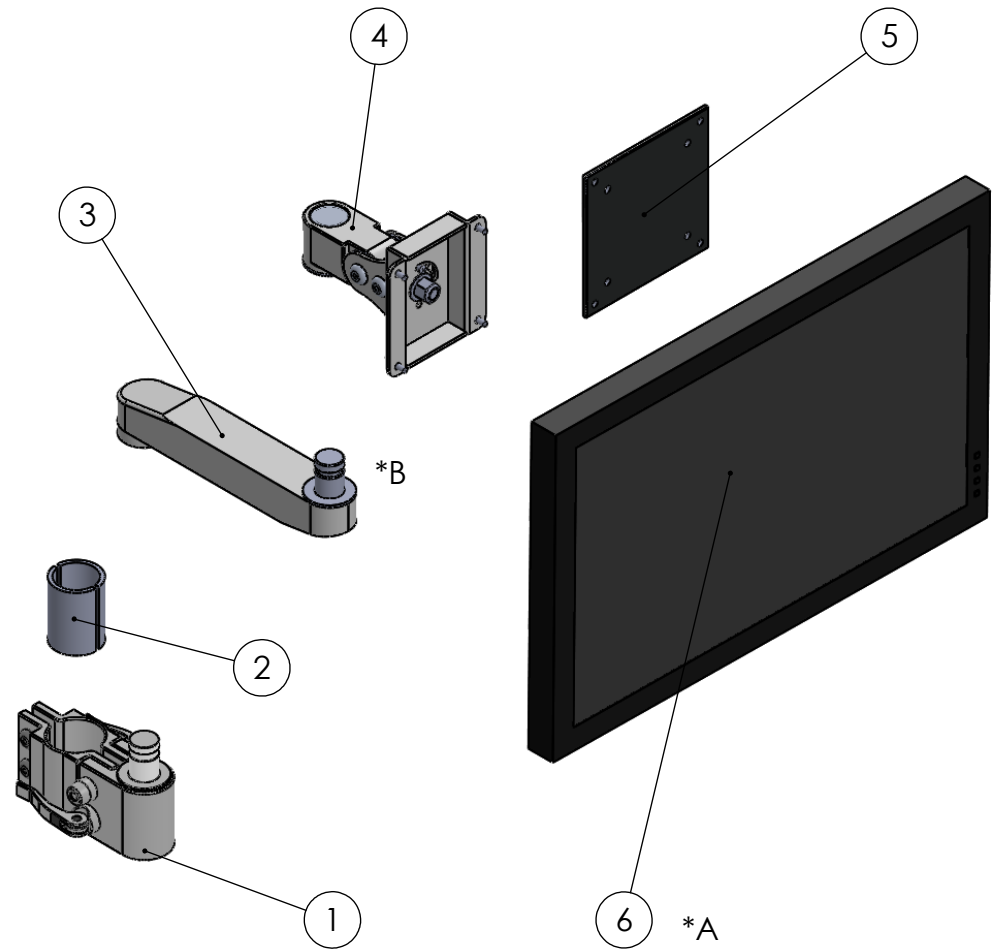

*A: Monitor NOT included in the assembly. Customer will provide own monitor.
 *B: Do NOT remove plastic ring from arm, arm will not function properly without it.

PROPRIETARY AND CONFIDENTIAL
 THE INFORMATION CONTAINED IN THIS DRAWING IS THE SOLE PROPERTY OF <INSERT COMPANY NAME HERE>. ANY REPRODUCTION IN PART OR AS A WHOLE WITHOUT THE WRITTEN PERMISSION OF <INSERT COMPANY NAME HERE> IS PROHIBITED.

		UNLESS OTHERWISE SPECIFIED:	NAME	DATE	TITLE: 60221P-10-65-B Assembly Drawing	
		DIMENSIONS ARE IN INCHES	DRAWN	SJB		06/21/17
		TOLERANCES: FRACTIONAL ±	CHECKED			
		ANGULAR: MACH ± BEND ±	ENG APPR.			
		TWO PLACE DECIMAL ±	MFG APPR.			
		THREE PLACE DECIMAL ±	Q.A.			
		INTERPRET GEOMETRIC TOLERANCING PER:	COMMENTS:			
NEXT ASSY	USED ON	MATERIAL				
		FINISH				
APPLICATION		DO NOT SCALE DRAWING	SIZE	DWG. NO.	REV	
			A	60221P-10-65-B		
			SCALE: 1:8	WEIGHT:	SHEET 2 OF 2	

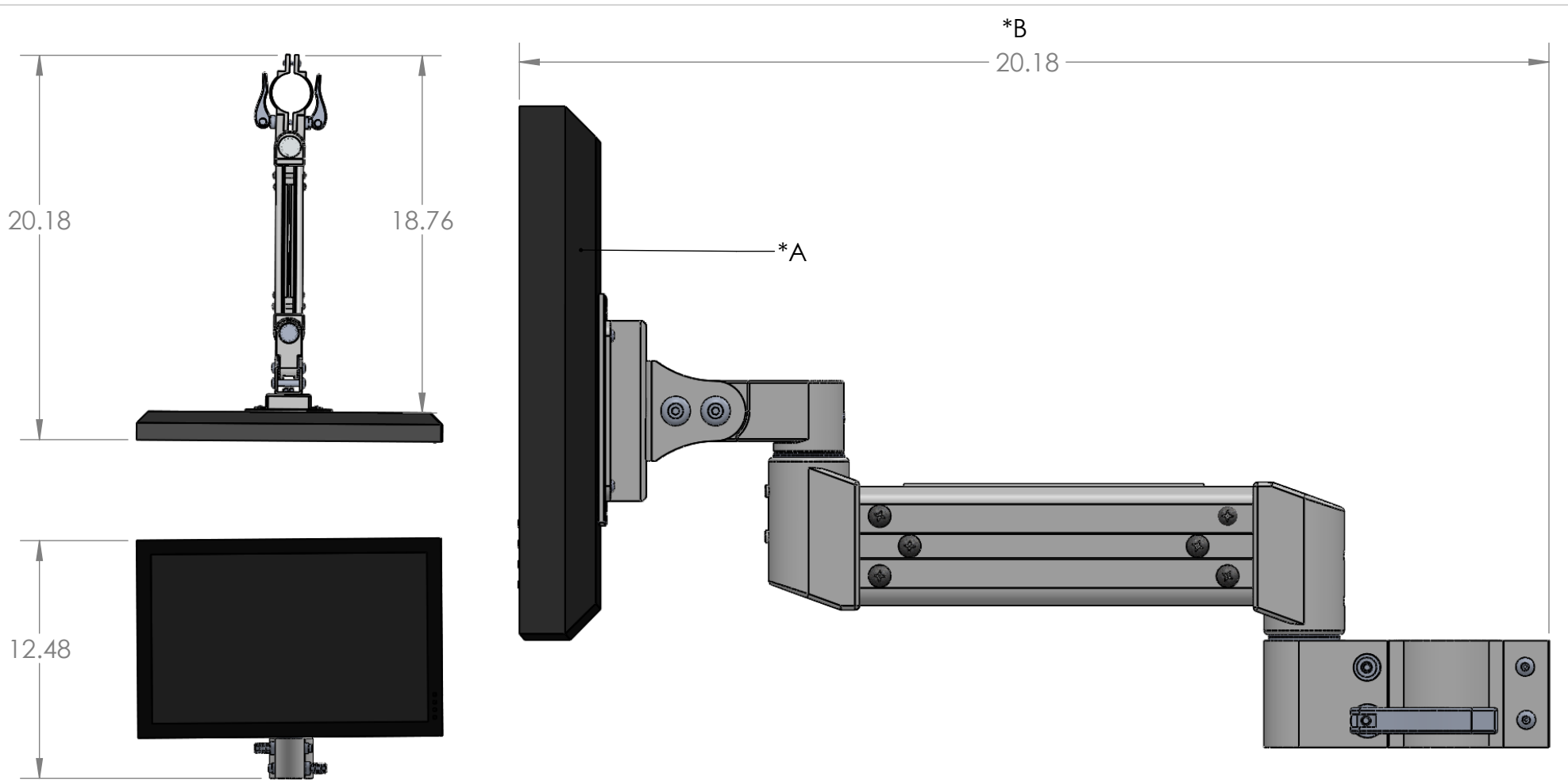

*A: Monitor shown is a standard 17" monitor, shown for concept and scale. Customer monitor dimensions may vary.
 *B: Dimensions shown are based on the angle of the 22-03-3 arm, dimensions may vary based on position.

PROPRIETARY AND CONFIDENTIAL
 THE INFORMATION CONTAINED IN THIS DRAWING IS THE SOLE PROPERTY OF <INSERT COMPANY NAME HERE>. ANY REPRODUCTION IN PART OR AS A WHOLE WITHOUT THE WRITTEN PERMISSION OF <INSERT COMPANY NAME HERE> IS PROHIBITED.

		UNLESS OTHERWISE SPECIFIED:		NAME	DATE	
		DIMENSIONS ARE IN INCHES	DRAWN	SJB	06/21/17	TITLE: 60221P-20-10-B
		TOLERANCES:	CHECKED			2" Pole Mounted Pivot Bracket with 10" arm
		FRACTIONAL ±	ENG APPR.			
		ANGULAR: MACH ± BEND ±	MFG APPR.			
		TWO PLACE DECIMAL ±	Q.A.			
		THREE PLACE DECIMAL ±	COMMENTS:			
		INTERPRET GEOMETRIC TOLERANCING PER:				SIZE DWG. NO. REV
		MATERIAL				A 60221P-20-10-B
NEXT ASSY	USED ON	FINISH				SCALE: 1:8 WEIGHT: SHEET 1 OF 2
APPLICATION		DO NOT SCALE DRAWING				

5

4

3

2

1

Drawing #: 60221P-20-10-B
 Assembly Drawing

ITEM	#60221P-20-10-B Parts	DESCRIPTION	QTY.
1	25-40-Q-B	Pole Bracket	1
2	22-03-3-B	10" Extension Arm	1
3	21-01-B	Pivot Bracket	1
4	21-02-B	Adaptor Plate	1
5	17" MON	17" Monitor (*A)	1

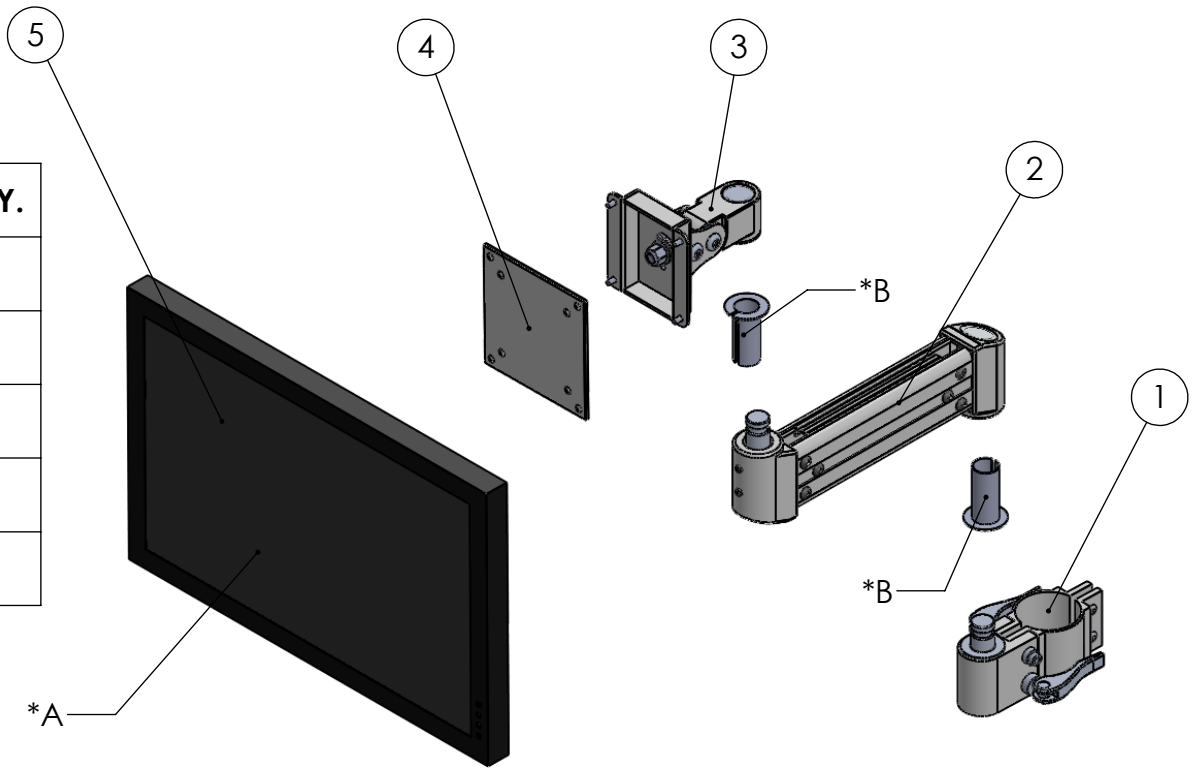

*A: Monitor NOT included in the assembly. Customer will provide their own monitor.
 *B: Do NOT remove plastic inserts from the arm, arm will not function properly without them.

PROPRIETARY AND CONFIDENTIAL
 THE INFORMATION CONTAINED IN THIS DRAWING IS THE SOLE PROPERTY OF <INSERT COMPANY NAME HERE>. ANY REPRODUCTION IN PART OR AS A WHOLE WITHOUT THE WRITTEN PERMISSION OF <INSERT COMPANY NAME HERE> IS PROHIBITED.

		UNLESS OTHERWISE SPECIFIED:	NAME	DATE	TITLE: 60221P-20-10-B Assembly Drawing	
		DIMENSIONS ARE IN INCHES	DRAWN	SJB		06/21/17
		TOLERANCES: FRACTIONAL ±	CHECKED			
		ANGULAR: MACH ± BEND ±	ENG APPR.			
		TWO PLACE DECIMAL ± THREE PLACE DECIMAL ±	MFG APPR.			
		INTERPRET GEOMETRIC TOLERANCING PER:	Q.A.			
		MATERIAL	COMMENTS:			
NEXT ASSY	USED ON	FINISH				
APPLICATION		DO NOT SCALE DRAWING				
SIZE	DWG. NO.	REV				
A	60221P-20-10-B					
SCALE: 1:8	WEIGHT:	SHEET 2 OF 2				